

# Frustrated Coupled Oscillators with Anomalous Coupling Method

Kazuki Ueta, Yoko Uwate and Yoshifumi Nishio  
 Dept. of Electrical and Electronic Engineering, Tokushima University  
 2-1 Minami-Josanjima, Tokushima 770-8506, Japan  
 Email: {kazuki, uwate, nishio}@ee.tokushima-u.ac.jp

**Abstract**—Synchronization phenomena of frustration network by coupled oscillators has been studied in a wide range of fields, such as medicine and engineering. It is investigated towards various systems up to now. However, analysis of regarding more complex systems are little. In our study, we developed the system model so that a basic minimum unit even in more complex systems. In addition, we observed synchronization phenomena about the system. In this paper, we show the result of circuit experiment with oscilloscope. Finally, we state the conclusion accompanying the experiment results.

## I. INTRODUCTION

There are a lot of synchronization phenomena in this world. This is one of the nonlinear phenomena that we can often observe by natural animate beings which do collective actions. For example, firefly luminescence, cry of birds and frogs, applause of many people and so on. Synchronization phenomena have a feature that the set of small power can produce very big power by synchronizing at a time. Therefore study of synchronization phenomena have been widely reported not only engineering but also the physical and biological fields[1]–[8]. Investigation of coupled oscillators attention from many researchers because coupled oscillatory network produces interesting phase synchronization such as the phase propagation wave, clustering and complex patterns.

In this study, we focus on the synchronization phenomena coupled by van der Pol oscillators containing ring and star structures. Van der Pol oscillator is structured by inductor, capacitor and nonlinearity resistor. Van der Pol oscillator has the feature of complicated oscillation pattern changing by frequency. Therefore, it can be approximated to any oscillation pattern in the natural world. We observe the synchronization phenomena with computer simulation. van der Pol oscillator is shown in Fig. 1.

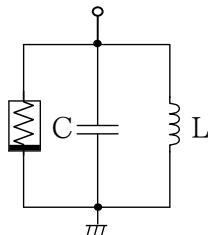

Fig. 1. van der Pol oscillator.

## II. SYSTEM MODEL

Figure 2 shows a system model constituted van der Pol oscillators (VDP-A and VDP-B). We couple each VDP-B via inductor  $L$  and ground by coupling resistor  $R$ . In addition, We couple VDP-A via resistor  $r$ . VDP-A is the only one central circuit which is connected to all VDP-B in this system by resistor  $r$ .

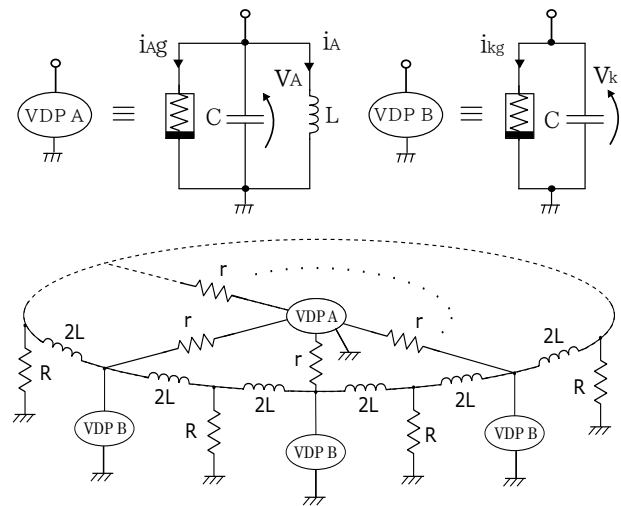

Fig. 2. System model.

In the computer simulations, We assume that the voltage  $v_k$  and ampere  $i_{kg}$  characteristics of the nonlinear resistor in each oscillator are given by the follows:

$$i_{kg} = -g_1 v_k + g_3 v_k^3, \quad (1)$$

$$(g_1, g_3 > 0), \\ (k = 1, 2, 3, \dots, N),$$

The characteristic of ring coupling has in-phase, anti-phase and N-phase. The characteristic of star coupling has in-phase and anti-phase.

First, the circuit equations of VDP-A are given as follows:

$$\begin{cases} C \frac{dv_k}{dt} = -i_n - i_{1g} + \frac{1}{R} \left( (N-1)v_k - \sum_{n=2}^N v_n \right), \\ L \frac{di_1}{dt} = v_k, \end{cases} \quad (2)$$

$$(n = 2, 3, \dots, N),$$

where  $N$  denotes the number of VDP-B.

On the other hand, VDP-B is connected to the adjacent VDP-B and VDP-A. The circuit equations of VDP-B are given as follows:

$$\begin{cases} C \frac{dv_n}{dt} = -i_{kg} - i_{nR} - i_{na} - i_{nb}, \\ 2L \frac{di_{na}}{dt} = v_n - R_0(i_{na} + i_{(n+1)b}), \\ 2L \frac{di_{nb}}{dt} = v_n - R_0(i_{nb} + i_{(n-1)a}). \end{cases} \quad (3)$$

By using the parameters and variables as follows:

$$\begin{aligned} i_n &= \sqrt{\frac{g_1 C}{3g_3 L}} y_c, \quad i_{na} = \sqrt{\frac{g_1 C}{3g_3 L}} y_n, \quad i_{nb} = \sqrt{\frac{g_1 C}{3g_3 L}} z_n, \\ v_k &= \sqrt{\frac{g_1}{3g_3}} x_c, \quad v_n = \sqrt{\frac{g_1}{3g_3}} x_n, \\ t &= \sqrt{LC} \tau, \quad " \cdot " = \frac{d}{d\tau}, \quad \alpha = g_1 \sqrt{\frac{L}{C}}, \\ \beta &= \frac{1}{R} \sqrt{\frac{L}{C}}, \quad \gamma = R_0 \sqrt{\frac{C}{L}}, \end{aligned} \quad (4)$$

where  $\alpha$  is the nonlinearity,  $\beta$  is the coupling strength,  $\gamma$  indicates the resistive component and  $y_n$  denotes the current of neighbor oscillator on coupling resistor  $R_0$ . The normalized circuit equations of VDP-A are given as follows:

$$\begin{cases} \dot{x}_c = \alpha x_c \left( 1 - \frac{1}{3} x_c^2 \right) - y_c + \beta \left\{ (N-1)x_c - \sum_{n=2}^N x_n \right\}, \\ \dot{y}_c = x_c. \end{cases} \quad (5)$$

The normalized circuit equations of VDP-B are given as follows:

$$\begin{cases} \dot{x}_n = \alpha x_n \left( 1 - \frac{1}{3} x_n^2 \right) - y_n - z_n - \beta (x_c - x_n), \\ \dot{y}_n = \frac{1}{2} \{ x_n - \gamma (y_n + z_{n+1}) \}, \\ \dot{z}_n = \frac{1}{2} \{ x_n - \gamma (y_n + z_{n-1}) \}. \end{cases} \quad (6)$$

### III. SIMULATION RESULT

#### A. Computer Simulation

We calculate Eqs. (5) and (6) using the Runge-Kutta method with the step size  $h = 0.02$ . We show the simulation result of the synchronization phenomena when  $N = 5$  in Fig. 3. In this figure, We show the attractor of each oscillator and

the horizontal axis is the voltage of each oscillator, and the vertical axis is the electric current of each oscillator. We set the parameters  $\alpha = 0.1$ ,  $\beta = 0.0075$  and  $\gamma = 0.02$ . In addition, We show the system model of  $N = 4$  in Fig. 4.

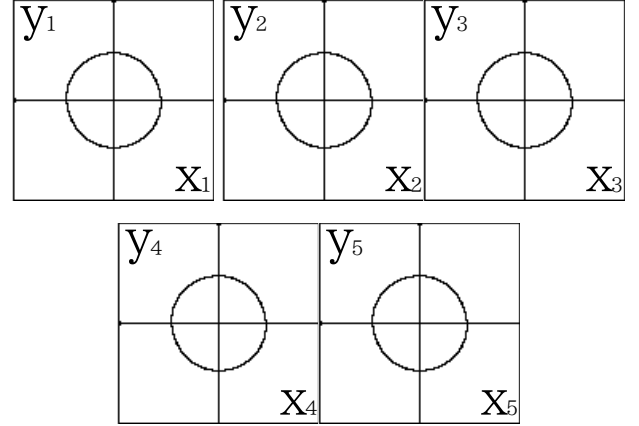

Fig. 3. Attractor between adjacent oscillators (horizontal axis:  $x_k$ , vertical axis:  $y_k$ ) ( $k = 1, 2, 3, 4, 5$ ).

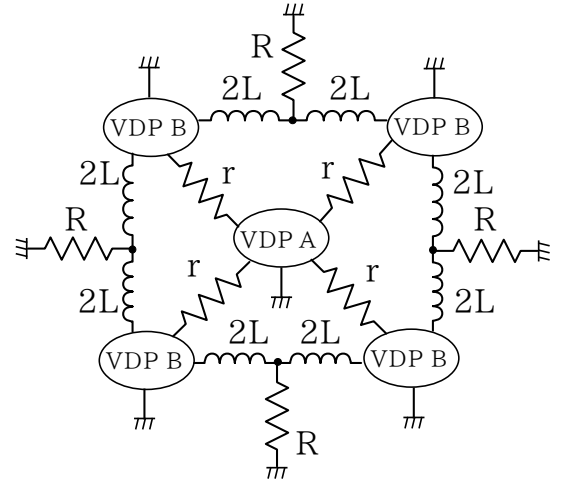

Fig. 4. System model of  $N = 4$ .

Next, the time waveforms of the voltage of each capacitor  $C$  after sufficient time has elapsed are shown in Fig. 5. And the phase differences between the adjacent oscillator of this case is equal to the result as shown in Fig. 6. It seems that two electric currents of VDP-B are piled up as we understand it from the figures like 3 phase.

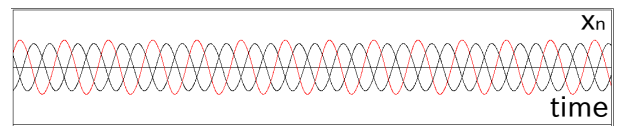

Fig. 5. The Time waveforms of the each oscillator for  $N = 4$ .

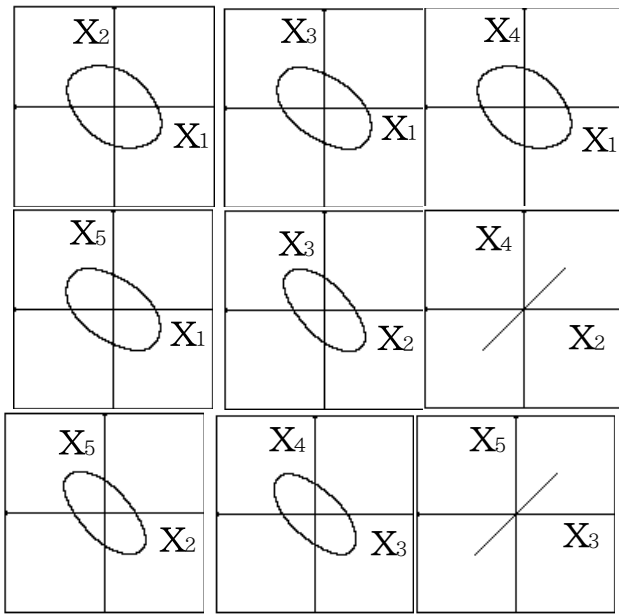
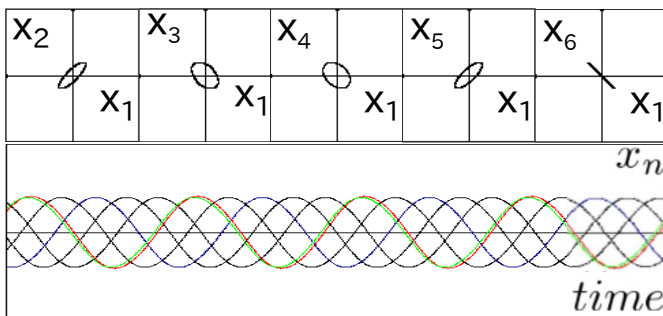

Fig. 6. Lissajous figures of  $N = 4$ .

Second, the simulation results of the system model containing six circuits are shown in Fig. 7. The value of the parameters are fixed with  $\beta=0.001$ ,  $0.0085$  and  $0.05$ . In the case of  $\beta=0.001$ , 5 phase synchronization appeared because the coupling strength of VDP-A is weak. The current of the VDP-A and one of the current of the VDP-B are in-phase at that time. Therefore, we assume 5 phase synchronization. When the value of  $\beta$  sets  $0.0085$ , some time waveforms of VDP-B come close on in-phase synchronization. When we increase coupling strength, most of two electric currents of VDP-B are piled up as we understand it from the Lissajous figures.

In the case of  $\beta=0.05$ , 5 phase synchronization become in-phase synchronization. And then VDP-A becomes anti-phase synchronization with VDP-B by increasing the value of  $\beta$ . We understand that VDP-B synchronizes even if we read either figure.



(a)  $\beta=0.001$ .

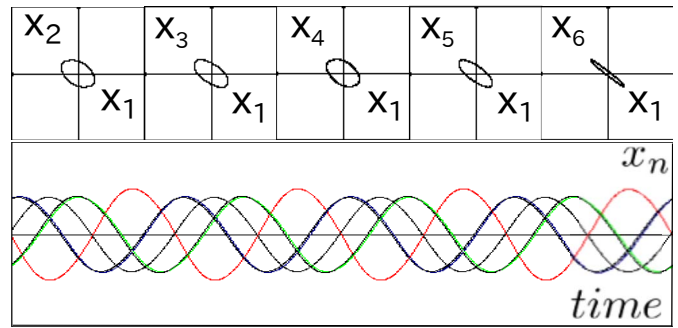

(b)  $\beta=0.0085$ .

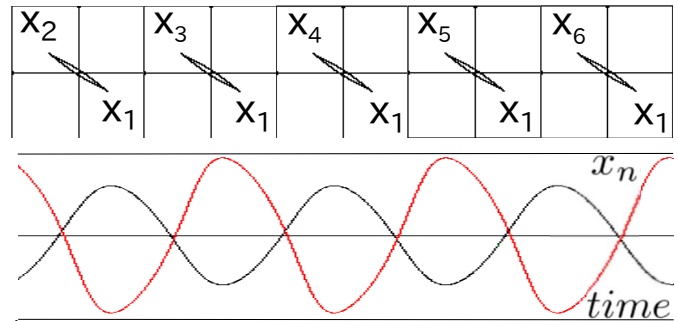

(c)  $\beta=0.05$ .

Fig. 7. Simulation Results for  $N=6$  ( $\alpha = 0.1$  and  $\gamma = 0.02$ ), time-waveform. Red and other colors denote  $x_1$  and  $x_n$  respectively. ( $n = 2, 3, \dots, 6$ )

**B. Relationship between coupling strength and phase difference**

Third, we summarize the simulation results in Fig. 8. In the figure, we show the results when we increase the circuit numbers  $N = 3, 4, \dots, 7$ . The phase difference is based on one voltage waveform of VDP-B. The broken line in the figure represent asynchronous. The solid line in the figure represent synchronous. From this result, It turns out that an even number circuits become in-phase as increasing the coupling strength. Similarly, It turns out that an even number circuits become in-phase as increasing the coupling strength. However, we couldn't confirm the synchronization state between  $\beta=0$  and  $\beta=0.016$  in an odd number circuits.

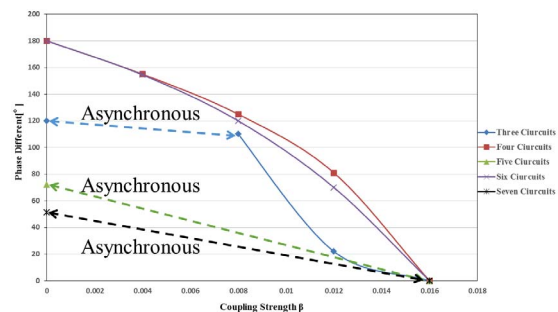

Fig. 8. Relationship between coupling strength and phase difference.

### C. Comparison with circuit experiment

Finally, we show the results of circuit experiment. In this experiment, we observed the waveform when  $N = 3$  with oscilloscope. From this results, we can observe that the 3 phase synchronized in-phase and anti-phase. Each VDP-B synchronised in-phase, VDP-A is anti-phase.

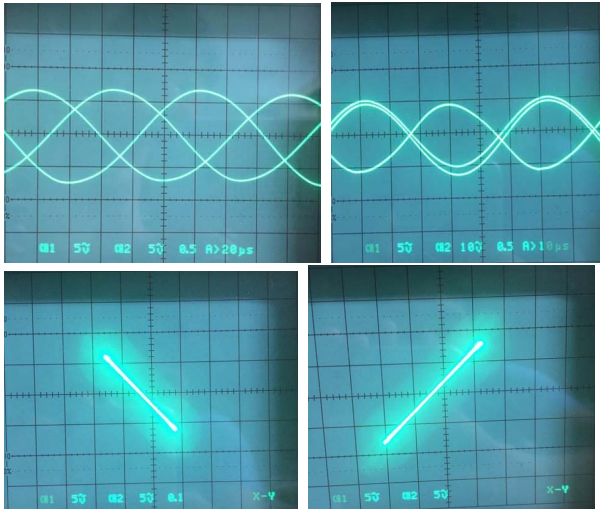

Fig. 9. Results of circuit experiment.

## IV. CONCLUSIONS

In this study, we have proposed a system model using five circuits that is combined the ring and star structures. We have observed the synchronization phenomena by increasing the coupling strength of ring. When the coupling strength is sufficiently small, system model becomes like function of ring coupling therefore,  $N$  phase or in-phase and anti-phase synchronization can be observed. By increasing the coupling strength, time wave forms of VDP-B have come close in-phase synchronization. When the coupling strength is sufficiently large, time wave forms of VDP-A and VDP-B become anti-phase synchronization. In the future, we investigate synchronization phenomena using other circuits.

## REFERENCES

- [1] D. J. Watts and S. H. Strogatz, "Collective dynamics of small-world", *Nature*, vol. 393, pp. 440-442, 1998.
- [2] A. L. Barabasi and R. Albert, "Emergence of scaling in random networks", *Science*, vol. 286, pp. 509-512, 1999.
- [3] S. H. Strogatz, "Exploring complex networks", *Nature*, vol. 410, pp. 268-276, 2001.
- [4] R. Albert and A. L. Barabasi, "Statistical mechanics of complex networks", *Rev. Modern Physics*, vol. 74, pp. 47-97, 2002.
- [5] L. M. Pecora and T. L. Carrol, "Synchronization in Chaotic Systems", *Physical Review Letters*, vol. 64, pp. 821-824, 1990.
- [6] K. Kaneko, "Spatiotemporal Intermittency in Coupled Map Lattices", *Progress of Theoretical Physics*, vol. 74, No. 5, pp. 1033-1044, 1985.
- [7] K. Kaneko, "Clustering, Coding, Switching, Hierarchical Ordering, and Control in a Network of Chaotic Elements", *Physica D*, vol. 41, pp. 137-172, 1990.
- [8] M. Shinriki, M. Yamamoto and S. Mori, "Multimode Oscillations in a Modified van der Pol Oscillator Containing a Positive Nonlinear Conductance", *Proc. IEEE*, vol. 69, pp. 394-395, 1981.